

LOCKING-PIN BUSHINGS

PRESS FIT: 8620 STEEL, CASE HARDENED, BLACK OXIDE FINISH
 THREADED: 1215 STEEL, CARBURIZE HARDENED, BLACK OXIDE FINISH

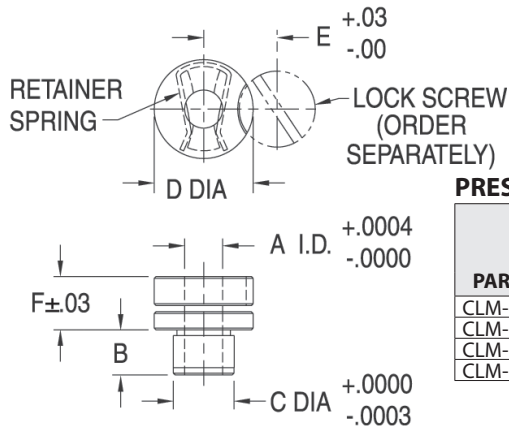

Press Fit



Locking-Pin Bushings are equipped with a retainer spring clip on the inside diameter. These bushings are used with all types of locking/captive pins and locating screws. Available for pin diameters 3/16 to 1/2" (6 to 12mm in metric). Some bushings are available in a choice of lengths, to suit thinner or thicker plates. Several bushing sizes are optionally available with an oversize ID (.040" larger), for applications with multiple pins where additional clearance is desired to prevent binding. Locking-Pin Bushings are designed to press fit in a standard reamed hole. Secure with a Lockscrew to positively hold the bushing in place – order separately as part number LS-1 (inch) or LSM-3 (metric).

PRESS FIT (INCH)

PART NO.	A DIA		B	C DIA		D DIA	E	F	MATCHING P BUSHING FOR BOTTOM PLATE
	NOMINAL	ACTUAL		NOMINAL	ACTUAL				
CL-3-LPB	3/16	.1868	.31	13/32	.4078	13/16	.62	.44	P-26-6-.1865
CL-4-LPB	1/4	.2493	.31						
CL-4A-LPB			.50						
CL-5-LPB	5/16	.3118	.31						
CL-5A-LPB			.37						
CL-5B-LPB			.50						
CL-6-LPB	3/8	.3743	.31	5/8	.6267				P-40-8-.3740
CL-6A-LPB			.50						
CL-8-LPB	1/2	.4993	.50	3/4	.7518	1-1/16	.75	P-48-12-.4990	
CL-8A-LPB			.75						

PRESS FIT (METRIC)

PART NO.	A DIA (mm)		B LENGTH UNDER HEAD (mm)	C DIA (mm)		D DIA (mm)	E (mm)	F (mm)	LOCKSCREW (ORDER SEPARATELY)	
	NOMINAL	ACTUAL		NOMINAL	ACTUAL					
CLM-6-LPB	6	5.982	Standard	8	10	10.038	22	16	12	LSM-3
CLM-8-LPB	8	7.982	Standard	10	13	13.043	22	16	12	LSM-3
CLM-10-LPB	10	9.982	Standard	12	16	16.043	22	16	12	LSM-3
CLM-12-LPB	12	11.982	Standard	18	20	20.046	26	18	12	LSM-3

PRESS FIT, WITH OVERSIZE ID (INCH)

PART NO.	A DIA		B	C DIA		D DIA	E	F	MATCHING P BUSHING FOR BOTTOM PLATE
	NOMINAL	ACTUAL		NOMINAL	ACTUAL				
CL-4-LPB-OS	1/4	.2643	.31	13/32	.4078	13/16	.62	.44	—
CL-5-LPB-OS	5/16	.3268	.31	1/2	.5017	13/16	.62	.44	—
CL-6-LPB-OS	3/8	.3893	.31	5/8	.6267	13/16	.62	.44	—
CL-8-LPB-OS	1/2	.5143	.50	3/4	.7518	1-1/16	.75	.44	—

PRESS FIT, WITH OVERSIZE ID (METRIC)

PART NO.	A DIA (mm)		B LENGTH UNDER HEAD (mm)	C DIA (mm)		D DIA (mm)	E (mm)	F (mm)	LOCKSCREW (ORDER SEPARATELY)	
	NOMINAL	ACTUAL		NOMINAL	ACTUAL					
CLM-6-LPB-OS	6	7	Standard	8	10	10.038	22	16	12	LSM-3
CLM-8-LPB-OS	8	9	Standard	10	13	13.043	22	16	12	LSM-3
CLM-10-LPB-OS	10	11	Standard	12	16	16.043	22	16	12	LSM-3
CLM-12-LPB-OS	12	13	Standard	18	20	20.046	26	18	12	LSM-3

Also available in threaded version!

Locking-Pin Bushings are now optionally available with a threaded OD, for installation in a tapped hole. This version is designed for use with clamping pins in non-locating applications, with an ID size .040" over nominal size.



Threaded

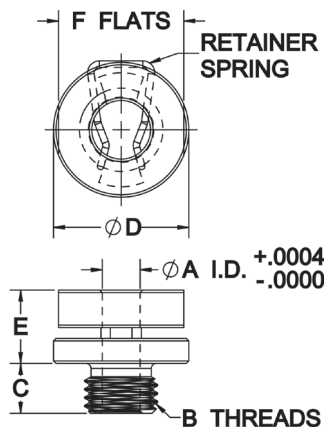

THREADED, WITH OVERSIZE ID (INCH)

PART NO.	A DIA		B THREAD	C	D DIA	E	F
	NOMINAL	ACTUAL					
CL-3-TLPB-OS	3/16	.2268	7/16-20	.300	.81	.44	3/4
CL-4-TLPB-OS	1/4	.2893	1/2-20				
CL-5-TLPB-OS	5/16	.3518	9/16-18				
CL-6-TLPB-OS	3/8	.4143	5/8-18	.350	1.06		1
CL-8-TLPB-OS	1/2	.5393	3/4-16	.375			

THREADED, WITH OVERSIZE ID (METRIC)

PART NO.	A DIA NOMINAL (mm)	A DIA ACTUAL OVERSIZE (mm)	B THREAD	THREAD PITCH (mm)	C (mm)	D DIA (mm)	E (mm)	F (mm)
CLM-6-TLPB-OS	6	7	M12x1.25	1.25	7.6	22	12	20
CLM-8-TLPB-OS	8	9	M16x1.5	1.5	7.6	22	12	20
CLM-10-TLPB-OS	10	11	M18x1.5	1.5	8.9	22	12	20
CLM-12-TLPB-OS	12	13	M20x1.5	1.5	8.9	26	12	24